



# Automatic Reciprocator



Model:COLO-2000D

Hang Zhou Color Powder Coating Equipment Co.,Ltd

Contact :sonne xie

Whatsapp/wechat: 0086 13396517032 [www.colo-international.com](http://www.colo-international.com)

## DESCRIPTION:

- 1.High-quality inverter. Digital intelligent model
  - 2.Wheel back and forth movements
  - 3.Standard travel: 1.5m/2m/2.5m(can be ordered)
  - 4.Four automatic spray gun rods(qty of the rods can be ordered)
- Color can be ordered

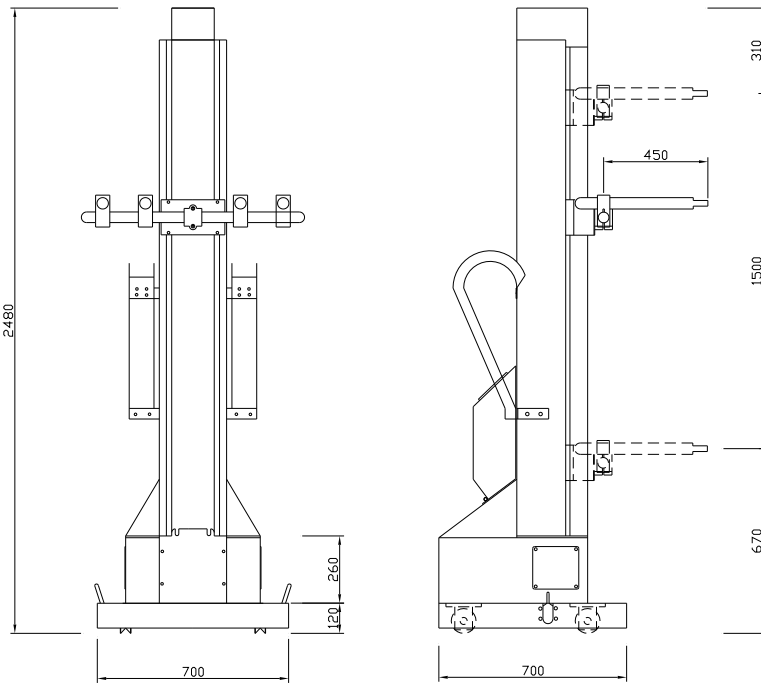

## SPECIFICATION:

CARRYING LOAD	25KGS
POWER SUPPLY	220V/50-60Hz
STROKE	1.5M
INPUT POWER	750W
SLIDING SPEED	5-30M/min

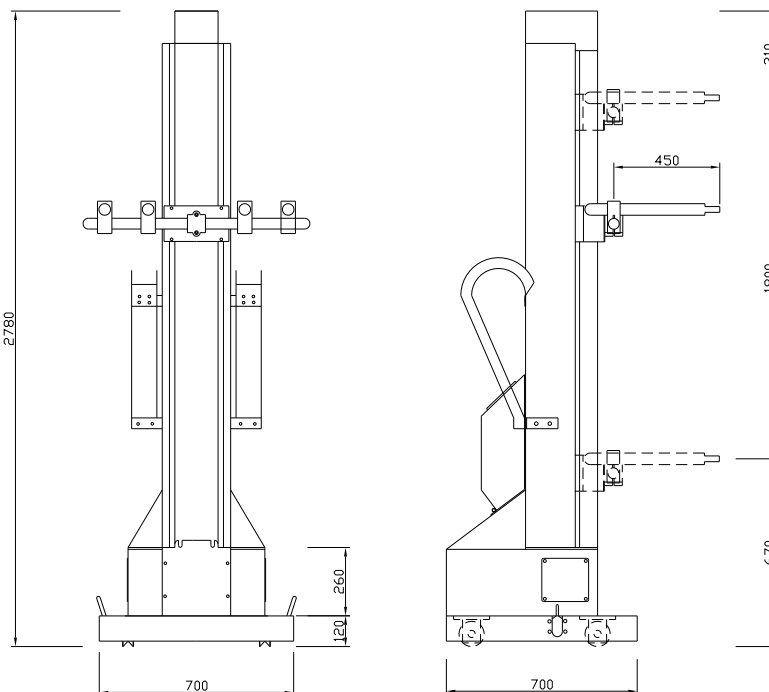

## SPECIFICATION:

CARRYING LOAD	25KGS
POWER SUPPLY	220V/50-60Hz
STROKE	1.8M
INPUT POWER	750W
SLIDING SPEED	5-30M/min

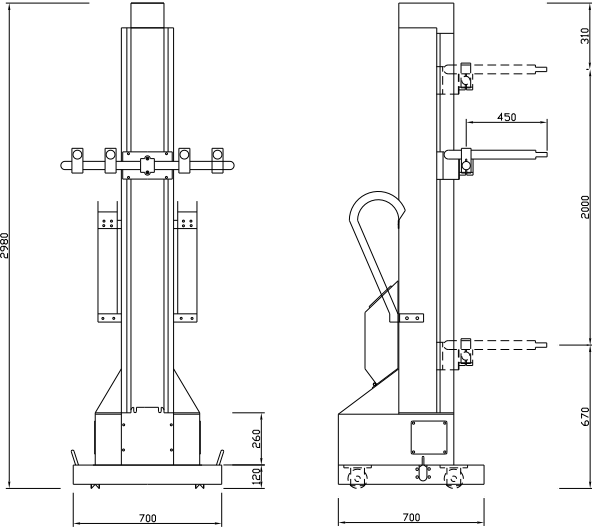

## SPECIFICATION:

CARRYING LOAD	25KGS
POWER SUPPLY	220V/50-60Hz
STROKE	2M
INPUT POWER	750W
SLIDING SPEED	5-30M/min

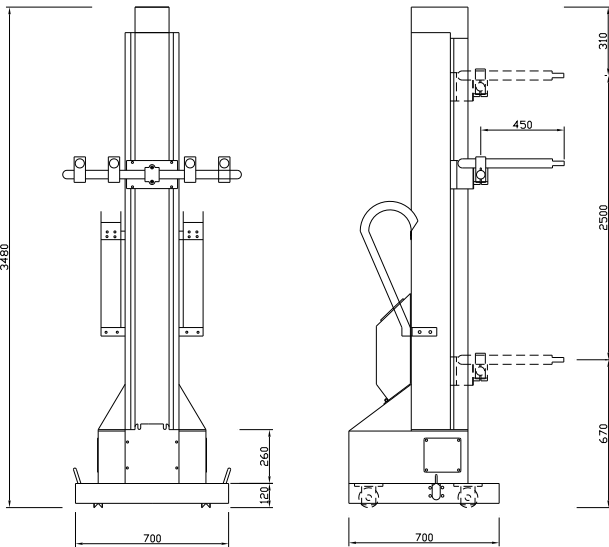

## SPECIFICATION:

CARRYING LOAD	25KGS
POWER SUPPLY	220V/50-60Hz
STROKE	2.5M
INPUT POWER	750W
SLIDING SPEED	5-30M/min